

Type of device: VERTICAL HANGING BUFFER

CAPACITIES AVAILABLE: 80, 100, 120, 140

PRODUCT ID: BuforPionWisz



## 1. PRODUCT DESCRIPTION

Hanging water buffer is a device dedicated to closed heating system. Buffer is constructed for storing domestic water, which can be used long after the source of heat is extinguished. It can also work as an alternative source of heat. However the most important role of this type of tank is to increase quantity of water in the heating

system as well as to optimize of energy usage by decreasing the frequency of switching on the furnance. The tank is designed for vertical work only.

**THE TANK DOES NOT REQUIRE MAGNESIUM ANODE**

**2. CONSTRUCTION:**

Tank body - made of black steel. The steel thickness presented below is dedicated to a given product capacity.

| CAPACITY<br>[L] | Lower and<br>upper bottom     | Tank body                        |
|-----------------|-------------------------------|----------------------------------|
|                 | steel sheet<br>thickness [mm] | steel sheet<br>thickness<br>[mm] |
| 80              | 4                             | 3                                |
| 100             | 4                             | 3                                |
| 120             | 4                             | 3                                |
| 140             | 4                             | 3                                |

The internal anti-corrosion layer - the tank is covered EPIDIAN - food grade epoxy resin atested by National Institute of Public Health NIH - National Research Institute.

The externam thermal insulation - it is made of cloased polyurethane foam PUR of about 5,5 centimeters thickness being the integral part of the tank. The external values of the buffer are enhanced by ecological leather, which can be removed when needed.

**3. INSTALLATION SAFETY**

The proces of instalation must be prepared by an installer with appropriate qualifications and in compliance with Occupational Health and Safety Rules. Before starting the installation, please read this user manual. The product should be installed in accordance with the intended use recommended by the Manufacturer. The installation cost is the responsibility of the Buyer/User. The manufacturer is not

responsible for device defects resulting from incorrect installation of the tank or by a person who does not have installation qualifications.

Installing the tank in places exposed to: low temperature/ freezing, high temperature/ steam/ explosion and other substances that accelerate corrosion or oxidation (e.g. chlorine, ammonia) is prohibited, and its effects release the Manufacturer from liability for the tank.

If the tank is installed in a non-standard place, the surface of which is exposed to rapid destruction in contact with water, the User is obliged to appropriately protect the surface against possible secondary damage. IT IS PROHIBITED TO USE THE TANK WITHOUT AN OPERATING SAFETY VALVE - regular inspection of the valve is recommended. You must also not prevent dripping from the safety valve (do not seal the valve, but specify the cause and replace it with a functional valve if necessary).

If the tank is installed in a closed heating system, an expansion vessel with a capacity of not less than 5% of the tank capacity should be installed, while if the tank is installed in an open system, the so-called expansion tank with a capacity of not less than 5% of the heater capacity should be installed.

#### 4. INSTALLATION

The tank should be placed on a durable surface in a vertical position (the only permissible form). It is necessary to install the tank in such a place that the user has easy access to the safety valve in the event of a failure of the device, the heat source or the safety valve itself. The distance from the tank cover to the ceiling should not be less than 30 cm. Do not interfere with the connections, e.g. by bending them. In accordance with Journal of Law 2015 point: 1422 each connector must be insulated. The appropriate water intake for the buffer is the water supply network, the water quality must meet the standards of Council Directive 98/83/EC of November 3, 1998. ref. Quality of water intended for human consumption and the corresponding legislation of the Republic of Poland (Journal of Laws of 2017, item 2294). There is a risk of discoloration of the water or a foreign odor if the device is connected to its own water intake, for which the Manufacturer is not responsible.

The installation begins with filling the tank with water by opening the valve at the utility water inlet and opening (completely until the air is released, i.e. until the water flows out in a continuous stream) at the water outlet from the tank. When the tank is filled with water, close the valve and make sure that all connections are tight - tighten them if necessary. The installer is obliged to install a safety valve. The tank works on the principle of gravity, and consequently the inlet of the hot heating medium into the buffer must be located higher than the outlet from the boiler.

There are many options for connecting the buffer in the heating system, including combining several heat sources, e.g. a boiler/ furnace (gas, coal, wood, pellets, eco-

pea), solar system, heat pump, fireplace. One of the simplest configurations is the scheme:

furnace => buffer => water conditioner => heaters

The permissible temperature for the buffer operation is maximum 90 degrees Celsius, the maximum working pressure of the buffer is 0.6 MPa.

It is important to use a dialectical connector that does not conduct electricity at the junction between the cold and hot water connectors of the tank and the installation cables. This solution eliminates contact of iron with copper, thus extending the life of the tank and preventing electrolysis (a phenomenon that is particularly active in water with an acidic pH (level <7)).

If the User decides to install an electric heater, it must be connected through a socket with a grounding pin and must be protected by a residual current circuit breaker. The device works properly when the entire heating installation has been properly constructed and secured.

## 5. USER MANUAL

**Important!** You must not use the tank without filling it with water and without properly working safety valve.

The device maintenance process must be carried out in accordance with current Occupational Health and Safety rules.

After installing the tank but before using it, rinse the tank by filling the tank with water, heating it to a temperature of 50 degrees Celsius, and then releasing the water through the tap at the furthest point in the installation, and then repeating the process one more time.

Once a month, you should heat the tank - heat water to 70 degrees Celsius to remove bacteria which may occur.

If an undesirable factor occurs - e.g. the risk of freezing water inside the tank, in this case water from the tank should be immediately removed. The appearance of fire in the close contact with the tank may cause it to burn.

In case of steam appearance at the hot water outlet, immediately open the water outlet/faucet and check the temperature of the heat source - reduce or turn off the heat source. If the device is connected to the electrical network, remove the plug from the power socket and find the cause of excessive temperature with the manufacturer of the heat source. The above situation may result in loss of health or life.

**ATTENTION!** The tank requires a flow of utility water of at least 20% of its capacity for 24 hours of operation. Precipitation of sediments and discoloration of water caused

by lack of tank operation, the so-called the temporary stagnation of the hot water circuit is not subject to complaint.

## TECHNICAL DRAWING

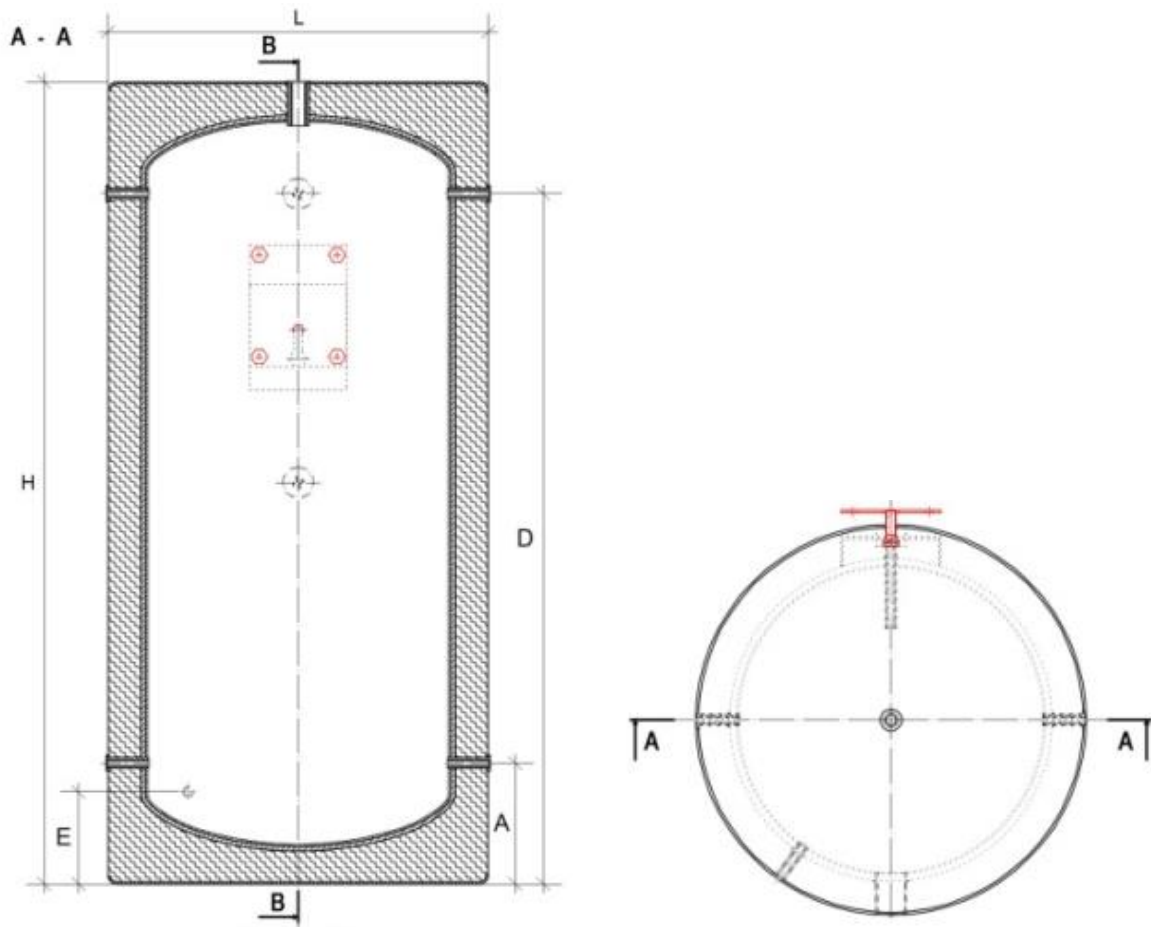

| SYMBOL           | CAPACITY | DIAMETER [L] | LENGHT [H] | DIAM. [A] | DIAM. [D] | DIAM. [E] |
|------------------|----------|--------------|------------|-----------|-----------|-----------|
| BuforPionWisz80  | 80 L     | 490 mm       | 945 mm     | 250 mm    | 685 mm    | 175 mm    |
| BuforPionWisz100 | 100 L    | 490 mm       | 1060 mm    | 280 mm    | 830 mm    | 200 mm    |
| BuforPionWisz120 | 120 L    | 490 mm       | 1180 mm    | 280 mm    | 950 mm    | 200 mm    |
| BuforPionWisz140 | 140 L    | 490 mm       | 1295 mm    | 280 mm    | 1065 mm   | 200 mm    |

## TECHNICAL DATA

| Technical Parameters   |    | Unit measure      | BuforPionWisz80L | BuforPionWisz100L | BuforPionWisz120L | BuforPionWisz140L |
|--|----|-------------------|------------------|-------------------|-------------------|-------------------|
| EPIDIAN - food grade epoxy resin- Anti-corrosion coating<br>THERMAL INSULATION - Closed polyurethane foam PUR                                |    |                   |                  |                   |                   |                   |
| Nominal capacity   |    | [L]               | 80               | 100               | 120               | 140               |
| Real capacity  |    | [L]               | 98               | 112               | 127               | 141               |
| Energy accumulated in the tank. Assumptions for the temperatures: domestic water 42°C; set in the tank 70°C; at the point of consumption 8°C |    | [L]               | 179              | 205               | 232               | 258               |
| Surface  |    | [m <sup>2</sup> ] | 1,5              | 1,6               | 1,8               | 1,9               |
| Weight   |    | [kg]              | 33               | 37                | 41                | 45                |
| Water tank maximum working temperature and pressure  |    | [°C / Bar]        | 90°C / 6 Bar     |                   |                   |                   |
| Downtime loss (S) in watt [W] for storage capacity in liters [L]   |    | [W]               | 25               | 26                | 27                | 28                |
| Heat losses depending on the capacity (V)  |    | [kWh/24h]         | 0,61             | 0,63              | 0,66              | 0,68              |
| <br>Energy class  | A+ |                   |                  |                   |                   |                   |
|  | A  |                   | A+               | A+                | A+                | A+                |
| <b>Dimentions</b>  |    |                   |                  |                   |                   |                   |
| Height   | H  |                   | 945              | 1060              | 1180              | 1295              |
| Diameter   | L  |                   | ø490             | ø490              | ø490              | ø490              |
| Connector - 5/4" or 6/4"   | A  | [mm]              | 250              | 280               | 280               | 280               |
|  | D  |                   | 685              | 830               | 950               | 1065              |
| Drain - 1/2"   | E  |                   | 175              | 200               | 200               | 200               |

\*The manufacturer reserves the right to the technical modifications/improvements in the product.

THE TANK DOES NOT REQUIRE MAGNESIUM ANODE

SCHEMA - VERTICAL HANGING BUFFER



LEGEND

- 1. POLYURETHANE FOAM THERMAL INSULATION
- 2. ANTI-CORROSION LAYER
- 3. CAPILLARY TUBE TEMPERATURE SENSOR 1/2"
- 4. DRAIN 3/4"
- 5. THERMOMETER 1/2"
- 6. CONNECTOR NO.1 - 5/4" or 6/4"
- 7. CONNECTOR NO. 2 - 5/4" or 6/4"
- 8. VENTING 5/4"
- 9. ELECTRIC HEATER WITH THEROMOSTAT 5/4"