

HORIZONTAL DOUBLE SHELL WATER EXCHANGER

CAPACITIES AVAILABLE: 80, 100, 120, 140, 160, 200, 250, 300

PRODUCT ID: DPWPozEPGC



AVAILABLE IN ECO LEATHER

OR WITHOUT



1. PRODUCT DESCRIPTION

Water exchanger designed for heating domestic water and keeping it hot for a long time. Thanks to the poliurethan foam used as thermal insulation water keeps warm up to 72h from the heating moment*. The exchanger is working both in open and

closed system. It is not limited by the type of the heating source as the tank is cooperating well with any of the heating solution. The additional heating shell used inside the tank is a very big advantage, which is making the water heating process much faster and considerably lowering the heating losses.

* Laboratory conditions

The product designed only to work in horizontal position only.

THE TANK DOES NOT REQUIRE MAGNESIUM ANODE

2. CONSTRUCTION:

Tank body - made of black steel. The steel thickness presented below is dedicated to a given product capacity.

CAPACITY [L]	Lower and upper bottom	Tank body
	steel sheet thickness [mm]	steel sheet thickness [mm]
80	4	3
100	4	3
120	4	3
140	4	3
160	4	3
180	4	3
200	4	3
250	4	3
300	4	3

The internal anti-corrosion layer - the tank is covered EPIDIAN - food grade epoxy resin atested by National Institute of Public Health NIH - National Research Institute.

The externam thermal insulation - it is made of cloased polyurethane foam PUR of about 5,5 centimeters thickness being the integral part of the tank. The external values of the buffer are enhanced by ecological leather, which can be removed when needed.

In the upper bottom of the horizontal tank there is: a connection to a 5/4" electric heater, a 1/2" circulation connection and an *input for a temperature sensor (*applies only to tanks with the capacity of 200L, 250L, 300L). The supply and return

to the central heating system is 1", while the supply and return to domestic hot water is 3/4". The tank can be installed anywhere thanks to the design and layout of the steel couplers. The power supply can operate as the return and the return can operate as the power supply. This applies to both the central heating boiler water connection as well as hot domestic water connection.

3. INSTALATION SAFETY

The proces of instalation must be prepared by an installer with appropriate qualifications and in compliance with Occupational Health and Safety Rules. Before starting the installation, please read this user manual. The product should be installed in accordance with the intended use recommended by the Manufacturer. The installation cost is the responsibility of the Buyer/User. The manufacturer is not responsible for device defects resulting from incorrect installation of the tank or by a person who does not have installation qualifications.

Installing the tank in places exposed to: low temperature/ freezing, high temperature/ steam/ explosion and other substances that accelerate corrosion or oxidation (e.g. chlorine, ammonia) is prohibited, and its effects release the Manufacturer from liability for the tank.

If the tank is installed in a non-standard place, the surface of which is exposed to rapid destruction in contact with water, the User is obliged to appropriately protect the surface against possible secondary damage. IT IS PROHIBITED TO USE THE TANK WITHOUT AN OPERATING SAFETY VALVE - regular inspection of the valve is recommended. You must also not prevent dripping from the safety valve (do not seal the valve, but specify the cause and replace it with a functional valve if necessary).

If the tank is installed in a closed heating system, an expansion vessel with a capacity of not less than 5% of the tank capacity should be installed, while if the tank is installed in an open system, the so-called expansion tank with a capacity of not less than 5% of the heater capacity should be installed.

4. INSTALATION

The tank should be placed on a durable surface in a horizontal position (the only permissible form). It is necessary to install the tank in such a place that the user has easy access to the safety valve in the event of a failure of the device, the heat source or the safety valve itself. The distance from the tank cover to the ceiling should not be less than 30 cm. Do not interfere with the connections, e.g. by bending them. In accordance with Journal of Law 2015 point: 1422 each connector must be insulated. The appropriate water intake for the buffer is the water supply network, the water quality must meet the standards of Council Directive 98/83/EC of November 3, 1998. ref. Quality of water intended for human consumption and the corresponding

legislation of the Republic of Poland (Journal of Laws of 2017, item 2294). There is a risk of discoloration of the water or a foreign odor if the device is connected to its own water intake, for which the Manufacturer is not responsible.

The installation begins with filling the tank with domestic water by opening the valve at the water supply and opening it (completely until it is vented, i.e. until the water flows out in a continuous stream) at the water outlet from the tank. Once the tank is filled with water, close the valve and make sure that all connections are tight - tighten if necessary. The installer is obliged to install a safety valve. **Next, fill the shell with boiler water (from central heating).** The tank works on the principle of gravity, consequently the inlet of the heated heating medium to the double shell exchanger must be located higher than the boiler outlet.

It is important to use a dialectical connector that does not conduct electricity at the junction between the cold and hot water connectors of the tank and the installation cables. This solution eliminates contact of iron with copper, thus extending the life of the tank and preventing electrolysis (a phenomenon that is particularly active in water with an acidic pH (level <7)).

A horizontal double shell water heater can be powered by any source of heat source in the heating system, e.g. boiler/ furnace, solar system, heat pump, fireplace.

The permissible temperature for the operation of the tank is a maximum of 70 degrees Celsius, the maximum working pressure of the tank is 0.6 MPa.

If the User decides to install an electric heater, it must be connected through a socket with a grounding pin and must be protected by a residual current circuit breaker. The device works properly when the entire heating installation has been properly constructed and secured.

5. USER MANUAL

Important! You must not use the tank without filling it with water and without properly working safety valve.

The device maintenance process must be carried out in accordance with current Occupational Health and Safety rules.

After installing the tank but before using it, rinse the tank by filling the tank with water, heating it to a temperature of 50 degrees Celsius, and then releasing the water through the tap at the furthest point in the installation, and then repeating the process one more time.

Once a month, you should heat the tank - heat water to 70 degrees Celsius to remove bacteria which may occur.

If an undesirable factor occurs - e.g. the risk of freezing water inside the tank, in this case water from the tank should be immediately removed. The appearance of fire in the close contact with the tank may cause it to burn.

In case of steam appearance at the hot water outlet, immediately open the water outlet/faucet and check the temperature of the heat source - reduce or turn off the heat source. If the device is connected to the electrical network, remove the plug from the power socket and find the cause of excessive temperature with the manufacturer of the heat source. The above situation may result in loss of health or life.

ATTENTION! The tank requires a flow of utility water of at least 20% of its capacity for 24 hours of operation. Precipitation of sediments and discoloration of water caused by lack of tank operation, the so-called the temporary stagnation of the hot water circuit is not subject to complaint.

TECHNICAL DRAWING:

Version in eco leather

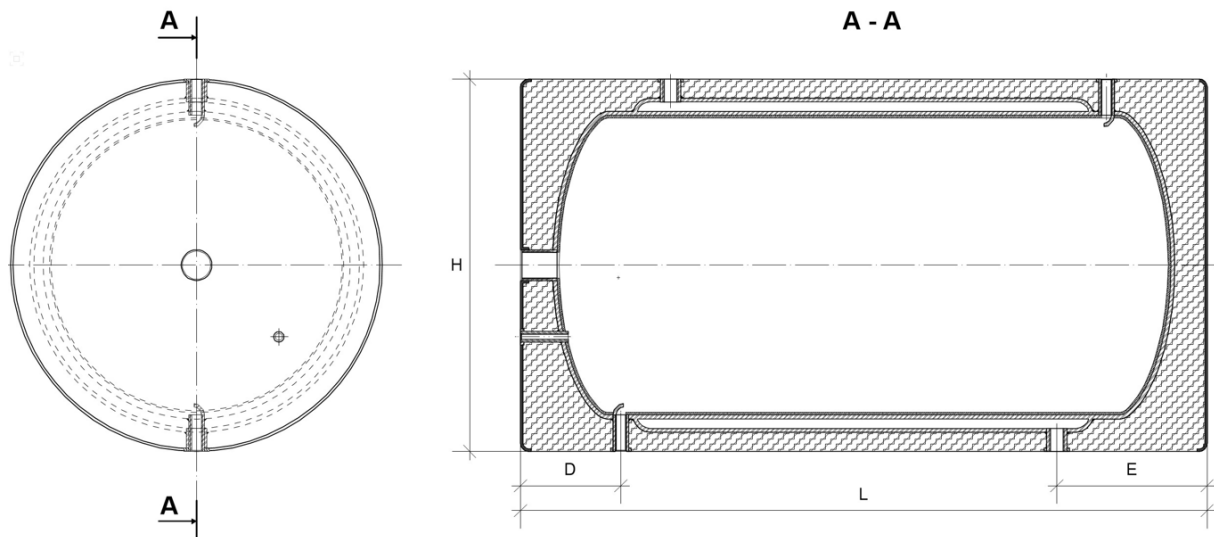

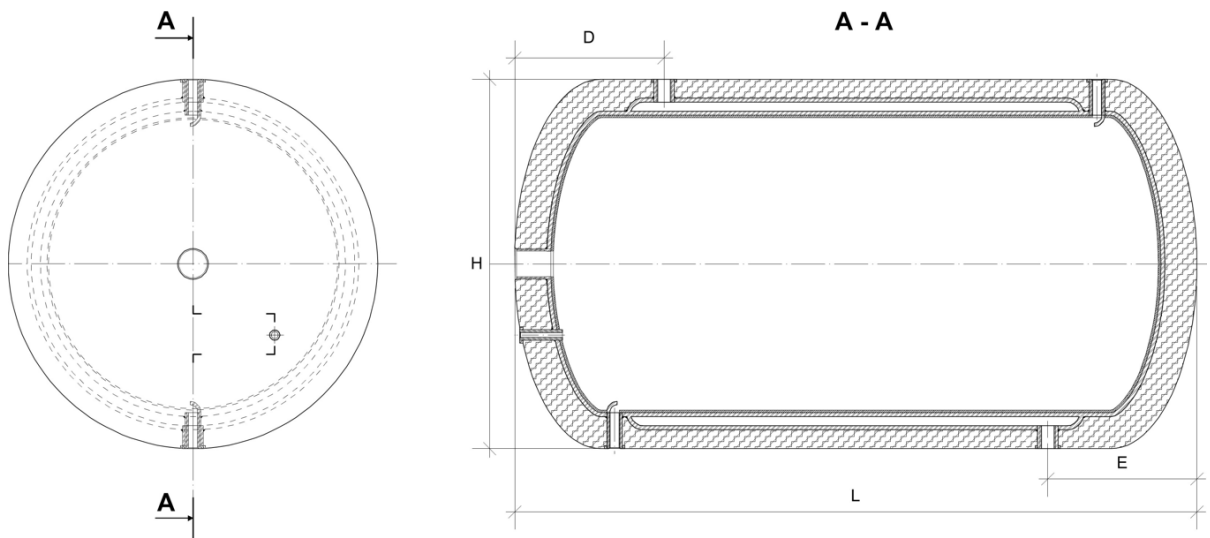

Version without eco leather



SYMBOL	CAPACITY	DIAMETER [H]	LENGHT [L]	DIAM. [D]	DIAM. [E]
DPWPozEPGC80	80 L	470 mm	800 mm	210 mm	210 mm
DPWPozEPGC100	100 L	470 mm	960 mm	210 mm	210 mm
DPWPozEPGC120	120 L	470 mm	1112 mm	210 mm	210 mm
DPWPozEPGC140	140 L	470 mm	1200 mm	210 mm	210 mm
DPWPozEPGC200	200 L	630 mm	1200 mm	180 mm	240 mm
DPWPozEPGC250	250 L	630 mm	1500 mm	180 mm	260 mm
DPWPozEPGC300	300 L	630 mm	1700 mm	240 mm	320 mm

TECHNICAL DATA ref. REGULATIONS

Technical Parameters		Unit measure	DPW/PozEPGC 80L	DPW/PozEPGC 100L	DPW/PozEPGC 120L	DPW/PozEPGC 140L	DPW/PozEPGC 200L	DPW/PozEPGC 250L	DPW/PozEPGC 300L
EPIDIAN - food grade epoxy resin- Anti-corrosion coating									
THERMAL INSULATION - Closed polyurethane foam PUR									
Nominal capacity	[L]		80	100	120	140	200	250	300
Actual capacity	[L]		98	112	127	141	241	299	355
Energy acumulated in the tank. Assumptions for the temperatures: domestic water 42°C; set in the tank 70°C; at the point of consumption 8°C	[L]		179	205	232	258	439	546	647
Efficiency	[L/h]		325	355	485	620	990	1165	1295
Exchanger power	[k/W]		19,0	19,5	24,0	31,0	37,0	44,0	51,0
Hot water demand	[m3/h]		1,4	1,4	1,6	1,6	2,1	2,4	2,7
Surface	[m²]		0,73	0,74	1,08	1,32	1,60	2,1	2,7
Weight	[kg]		27	32	37	42	57	72	85
Water tank maximum working temperature and pressure	[°C / Bar]		70°C / 6 Bar						
Downtime loss (S) in watt [W] for storage capacity (V) in liters [L]	[W]		25	26	27	28	34	36	39
Heat losses depending on the capacity (V)	[kWh/24h]		0,61	0,63	0,66	0,68	0,81	0,87	0,93
 Energy class			A+	A+	A+	A+	A	A	A
Dimintions									
Length	L		800	960	1112	1200	1200	1500	1700
Diameter	H		ø470	ø470	ø470	ø470	ø630	ø630	ø630
	D	[mm]	210	210	210	210	180	180	240
CONNECTOR - 5/4" or 6/4"	E		210	210	210	210	240	260	320

*The manufacturer reserves the right to the technical modifaicions/improvements in the product.

SCHEMA - HORIZONTAL DOUBLE SHELL WATER EXCHANGER

Version without eco leather

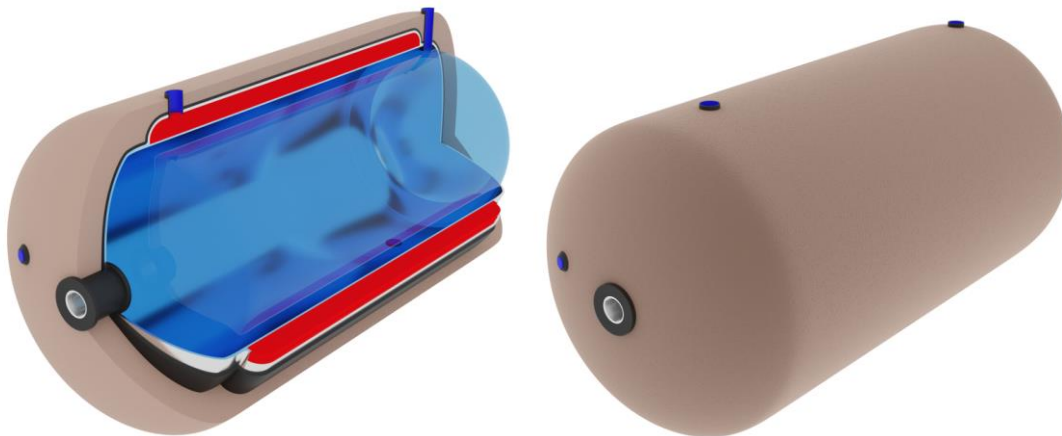

Version in eco leather

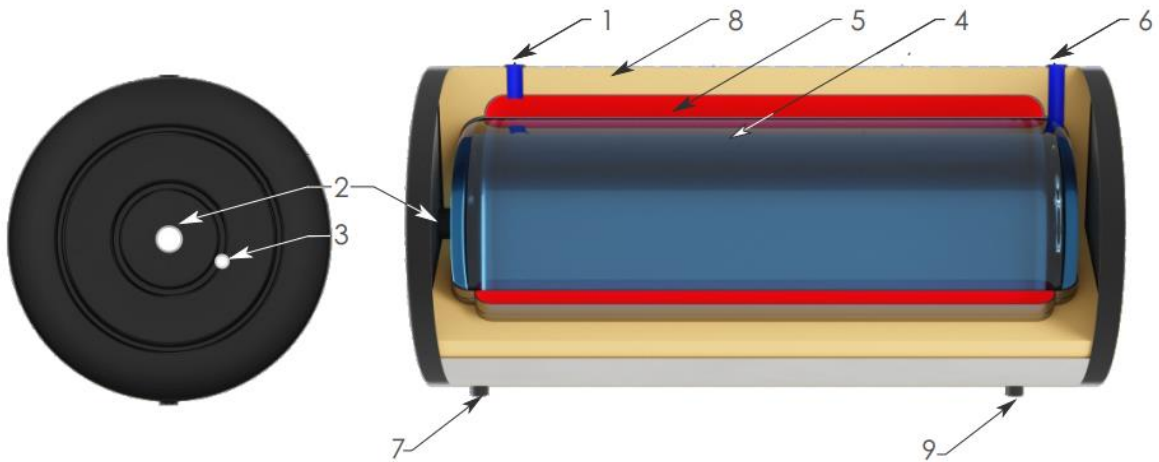

LEGEND

1. SUPPLY (CENTRAL HEATING) 1"
2. ELECTRIC HEATER WITH THERMOSTAT 5/4"
3. WATER CIRCULATION
4. ANTI - CORROSION LAYER
5. COAT (CENTRAL HEATING)
6. DOMESTIC WATER INTAKE 3/4"
7. DOMESTIC WATER SUPPLY 3/4"
8. POLYURETHANE FOAM
THERMAL INSULATION
9. WATER RETURN (CENTRAL HEATING) 1"